



FORTRESS[®]
FASTENERS

Abrasive Range

LUKAS

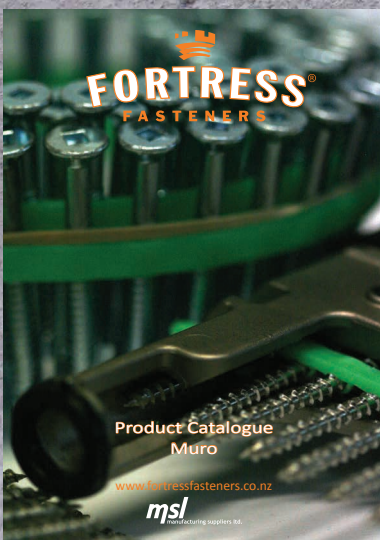
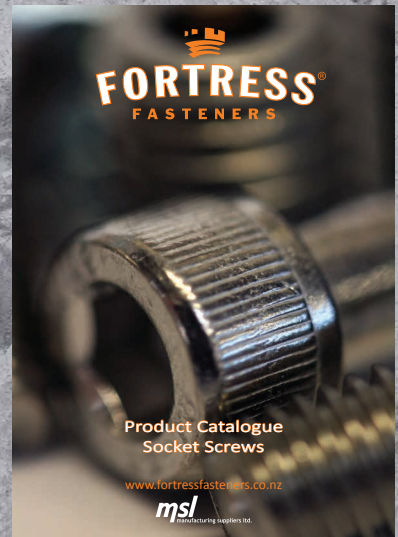
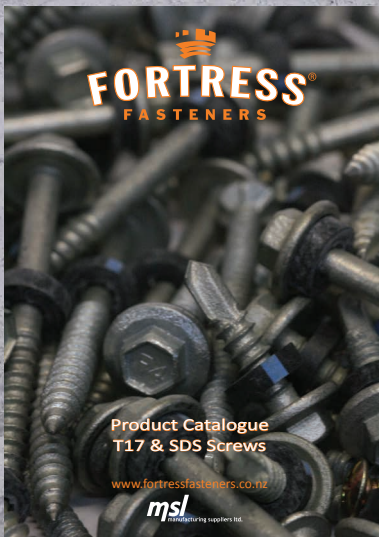
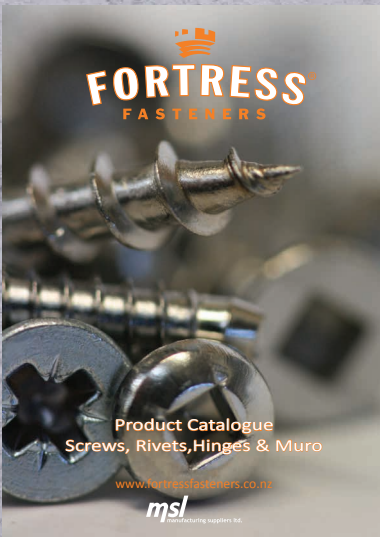
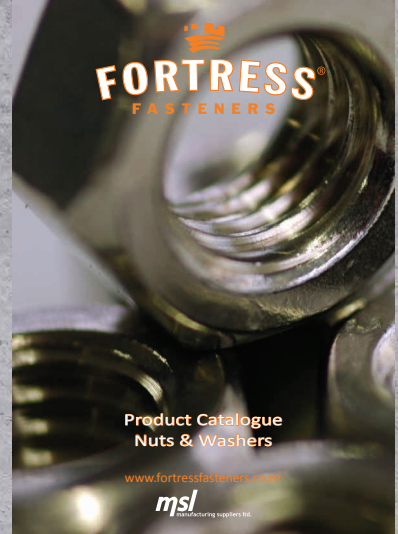
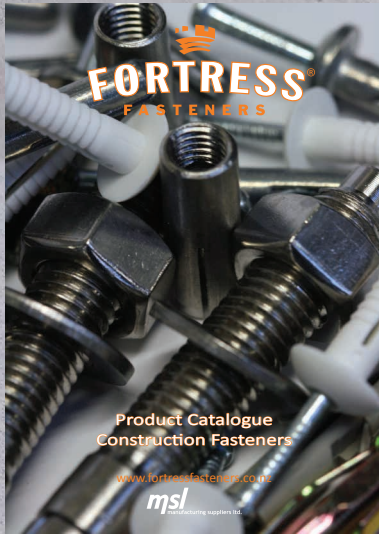
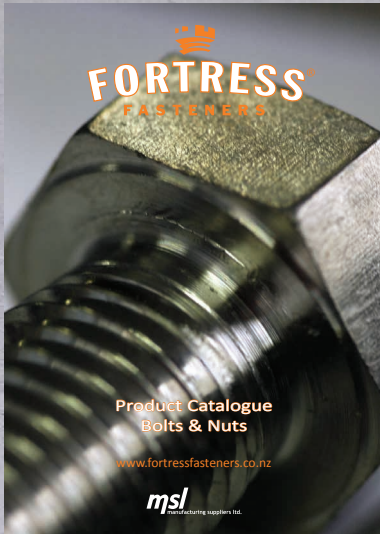

Fortress Catalogues Now Available





Manufacturing Suppliers Ltd (MSL) began business in 1980 as a small operation in New Lynn, Auckland and is now one of New Zealand's leading fastener suppliers. We have grown dramatically in the past thirty years and now employ over one hundred people who continue our company vision - to meet industry demands for a range of quality fasteners backed by a dependable service.

Now a wholly owned subsidiary of Steel & Tube Holdings Ltd, we take pride in supporting the New Zealand economy, and can now offer a full range of steel solutions in partnership with Steel & Tube.

Our substantial growth since the eighties has included the introduction of 9 branches nationwide. Fortress has developed into a house hold name across many kiwi industries. Our local management means we understand the local market and have the ability to make decisions rapidly and easily. Large enough to meet the demands of any customer, we are still small enough to offer the personal touch.

With our network of fully-stocked branches carrying over 300 million items and 17,000 product lines. This makes us arguably the largest fastening wholesaler in the country. Our new products, creative packaging and merchandising initiatives have also earned us a reputation as industry innovators.

We owe our success to our ability to deliver on time and in full to a wide customer base in manufacturing industries, the building trade and to building supplies merchants in New Zealand.

This, combined with the strength of our own Fortress brand and our exceptional customer service is what makes MSL a market leader.

Our national management means we understand the local market and have the ability to make decisions rapidly and easily. Large enough to meet the demands of any customer, we are still small enough to offer the personal touch.

Branch Network

Auckland (Head Office)

560 Rosebank Road, Avondale
Phone 09 828 2777
Fax 09 828 2424

Albany

Unit 4, 4 William Pickering Drive
Phone 09 414 7620
Fax 09 414 7410

Hamilton

51 Vickery Street, Te Rapa
Phone 07 850 8434
Fax 07 850 5696

Mount Maunganui

7 Newton Street
Phone 07 575 0508
Fax 07 575 0557

Hastings

199 St. Aubyn Street West
Phone 06 873 3311
Fax 06 873 3315

New Plymouth

62 De Havilland Drive, Bell Block
Phone 06 8248950 or 06 8248951
Fax 06 7574391

Palmerston North

94 Kaimanawa Street
Phone 06 355 5990
Fax 06 355 5880

Wellington

6 Regent Street, Petone
Phone 04 586 2300
Fax 04 586 2600

Christchurch

66 Hammersmith Drive, Sockburn
Phone 03 343 6740
Fax 03 343 6741



Contents

- P14 Cut off Discs - Inox
- P15 Cut off Discs - Steel
- P16 Flap Discs
- P17 Grinding Discs
- P18 Fibre discs - Ceramic
- P19 Fibre discs - Aluminium Oxide
- P20 Backing Pads
- P21 Barrell Rolls
- P22 Flap Wheels
- P28 Carbide Burrs
- P31 Diamond Cut off Wheels

A new partnership has been formed!!!



We at Fortress Fasteners are excited to announce that we have partnered up with one of the most reputable Abrasive brands on the market globally.

The Lukas brand have been in the Abrasive business for over 80 years with an extensive offering to this market.

We at Fortress believe this adds significant value to the Fortress brand and will increase our offering to our very diverse product range.





1937

Foundation of Gebrüder Lukas Werkzeuge und Maschinen OHG

1941

Addition of grinding discs and mounted grinding points to production range

1975

Merger of Gebrüder Lukas Werkzeuge und Maschinen OHG and Rheinische Zahnbohrer und Kleinfräserfabrik Baumann & Co. to form today's company

1986

Start of cutting and grinding disc production

The **LUKAS** value proposition

"Always the Right Tool" As a family business we have honoured this proposition every day for 80 years now. Very early we responded to the requests for individual tailor-made solutions and thus set the standard for the market. Today we are the internationally recognized specialist for innovative solutions and the production of high-performance tools. With 800 employees, three state-of-the-art production sites, an enormous wealth of experience and a broad product portfolio LUKAS is well established in the market. Socially accepted, customer-focused, flexible and highly innovative.



Since 1937 Always the Right Tool

More content available online

2017

80 years "Always the Right Tool"

2011

Acquisition of Schleifscheibenfabrik Rottluff GmbH in Chemnitz

2010

Opening of the logistics center in Engelskirchen

2004

Opening of the „TECHNIKUM“ training and demonstration center

1994

Completion of new company premises in Skalna, Czech Republic

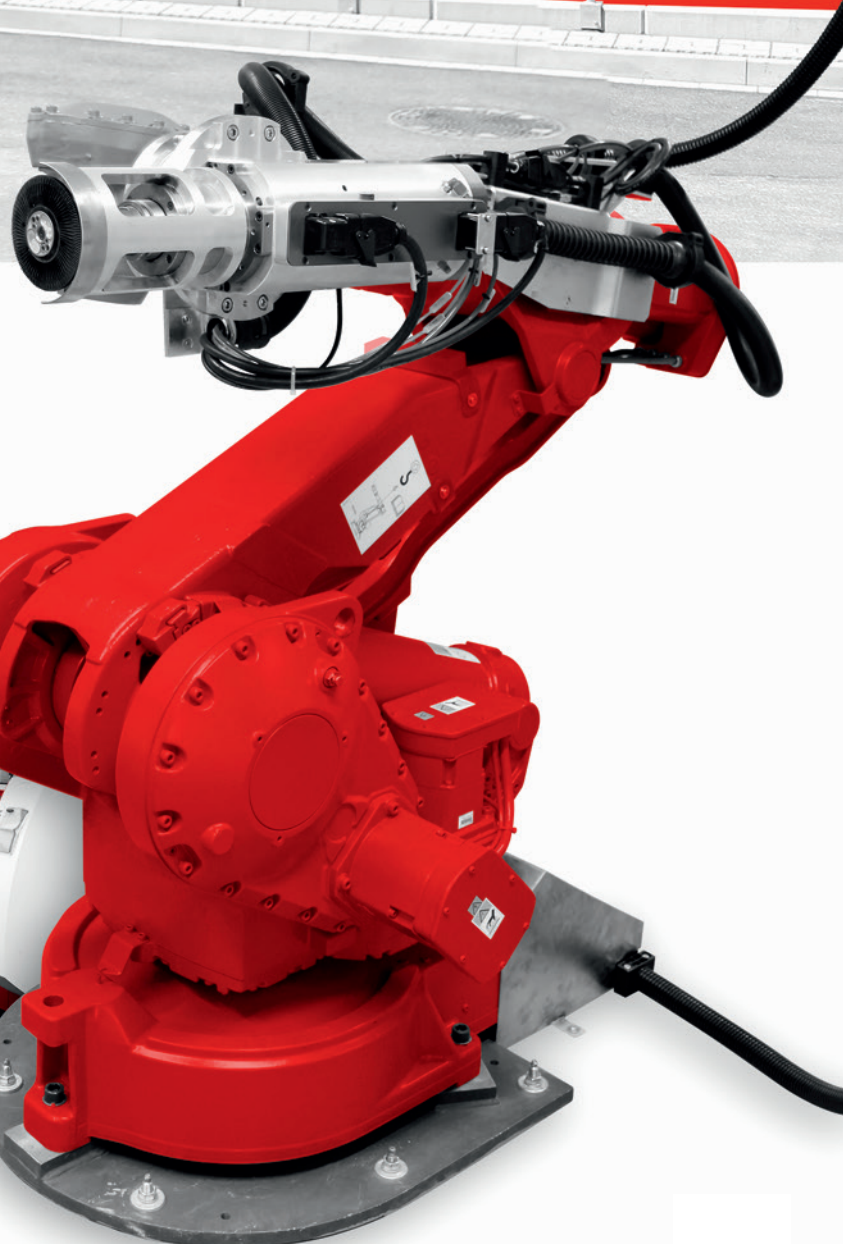

10.000

special solutions and various innovations in use throughout the world

250

days a year are dedicated to passing on our know-how

39

registered patents

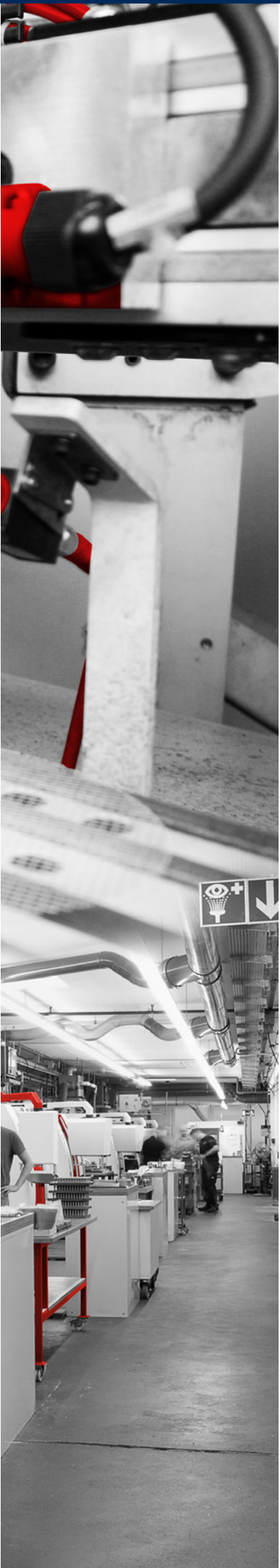

LUKAS quality

We don't talk about quality, we let it speak for itself. Every day, and in everything we do. This practice makes LUKAS tools a safe, reliable factor in your manufacturing process and ensures the best possible production quality.

- made in Germany
- top quality raw material
- state-of-the-art test facilities
- Quality management system according to EN ISO 9001:2015
- active membership in trade associations



Safety

With regards to occupational safety and operational convenience, LUKAS responsibility to the customer is taken very seriously. Our products are designed, manufactured and produced in accordance with the most stringent quality standards to provide a maximum of customer value at minimum risk. We are a member of both, the German Abrasive Association (VDS) and the Organisation for the Safety of Abrasives (oSa) and thus actively contribute to users' health and safety.

Applied standards:

- Safety Requirements for Bonded Abrasives Products: EN12413
- Safety Requirements for Diamond Blades: EN13236



Safety recommendations

- Don't handle wheels roughly.
- Don't use non-reinforced cut-off wheels on portable machines.
- Don't store wheels in a damp atmosphere or in extreme temperatures.
- Don't mount a damaged wheel.
- Don't ever exceed the maximum operating speed marked on the wheel.
- Don't force a wheel onto a machine spindle.
- Don't use mounting flanges which are incorrect, damaged, dirty or burred.
- Don't tighten the mounting nut or locking flange excessively. To do so can distort the flanges and discs.
- Don't use a machine without a wheel guard.
- Don't use wheels without proper ventilation or dust protection equipment.
- Don't apply side pressure to cut-off wheels. You should not bend the wheel.
- Don't stop the wheel by applying pressure to the periphery or face. Always switch the machine off and allow the wheel to stop revolving.
- Don't allow the wheel to be trapped or pinched in the cut.
- Don't apply excessive pressure onto the wheel so that the driving motor slows down.
- Don't drop or lower a portable machine by the cable or airline onto the floor. A wheel can be easily cracked, if it is put down hard, by the weight of the machine. This is a common cause of wheel breakage.
- Don't grind with a depressed centre grinding wheel at an angle below 30 degrees to the work piece.
- Don't use a machine in a position where you do not have full control of the machine and you are not well balanced.

Clamping System

The use of flanges with unequal diameters is not allowed. Both flanges between which the bonded abrasive is mounted must have the same outer diameter and similar contact areas (according to EN60745-2-3:2007 and ANSI B.71).

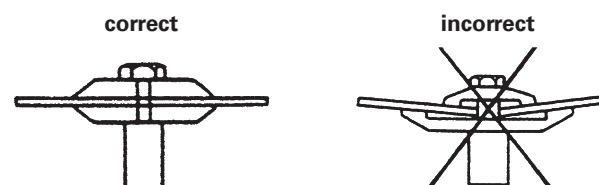



Cut off Discs

Inox



PART #		PACK QTY
CUT1001	100 x 1 x 16 LUKAS CUT OFF A60Z-BF Inox (PROGRESS) (50)	50
CUT10016	100 x 1.6 x 16 LUKAS CUT OFF A46Z-BF Inox (PROGRESS) (50)	50
CUT1151	115 x 1 x 22 LUKAS CUT OFF A60Z-BF Inox (PROGRESS) (50)	50
CUT11516	115 x 1.6 x 22 LUKAS CUT OFF A46Z-BF Inox (PROGRESS) (50)	50
CUT11525	115 x 2.5 x 22 LUKAS CUT OFF A30Z-BF Inox (PROGRESS) (25)	25
CUT1251	125 x 1 x 22 LUKAS CUT OFF A60Z-BF Inox (PROGRESS)	50
CUT12516	125 x 1.6 x 22 LUKAS CUT OFF A46Z-BF Inox (PROGRESS)	25
CUT12525	125 x 2.5 x 22 LUKAS CUT OFF A30Z-BF Inox (PROGRESS)	25
CUT18016	180 x 1.6 x 22 LUKAS CUT OFF A46Z-BF Inox (PROGRESS)	25
CUT18025	180 x 2.5 x 22 LUKAS CUT OFF A30Z-BF Inox (PROGRESS)	25
CUT23019	230 x 1.9 x 22 LUKAS CUT OFF A46Z-BF Inox (PROGRESS)	25
CUT23025	230 x 2.5 x 22 LUKAS CUT OFF A30Z-BF Inox (PROGRESS)	25



Cut off Discs

Inox



PART #		PACK QTY
CUT11510P	115 x 1 x 22 LUKAS CUT OFF A60Z-BF Inox (PROGRESS) 10 PACK	10
CUT12510P	125 x 1 x 22 LUKAS CUT OFF A60Z-BF Inox (PROGRESS) 10 PACK	10



Cut Off Discs

Steel



PART #		PACK QTY
CUT23030PF	230 x 3.0 x 22 LUKAS CUT OFF A24R-BF Steel (PREMIUMFLEX)	25
CUT30026LS	300 X 2.6 X 25 LUKAS CUT OFF A36-BF STEEL 80m/s(PREMIUMFLEX) (10)	10
CUT35026LS	350 X 2.6 X 25 LUKAS CUT OFF A36-BF STEEL 80m/s (PREMIUMFLEX) (10)	10
CUT40032LS	400 X 3.2 X 25 LUKAS CUT OFF A36-BF STEEL 80m/s (PREMIUMFLEX) (5)	5
CUT3004HS	300 X 4 X 20 LUKAS CUT OFF (PREMIUMFLEX) STEEL 100m/s (10)	10
CUT3504HS	350 X 4 X 25 LUKAS CUT OFF (PROMAX) STEEL 100m/s (10)	10
CUT4004HS	400 X 4 X 25 LUKAS CUT OFF (PROMAX) STEEL 100m/s (5)	5



Flap Discs

Zirconia



PART #		PACK QTY
FLAP10040	100 X 16 LUKAS FLAP DISC SLTR ZIRCONIA 40 GRIT (10)	10
FLAP10060	100 X 16 LUKAS FLAP DISC SLTR ZIRCONIA 60 GRIT (10)	10
FLAP10080	100 X 16 LUKAS FLAP DISC SLTR ZIRCONIA 80 GRIT (10)	10
FLAP11536	115 X 22 LUKAS FLAP DISC SLTR ZIRCONIA 36 GRIT (10)	10
FLAP11540	115 X 22 LUKAS FLAP DISC SLTR ZIRCONIA 40 GRIT (10)	10
FLAP11550	115 X 22 LUKAS FLAP DISC SLTR ZIRCONIA 50 GRIT (10)	10
FLAP11560	115 X 22 LUKAS FLAP DISC SLTR ZIRCONIA 60 GRIT (10)	10
FLAP11580	115 X 22 LUKAS FLAP DISC SLTR ZIRCONIA 80 GRIT (10)	10
FLAP115120	115 X 22 LUKAS FLAP DISC SLTR ZIRCONIA 120 GRIT (10)	10
FLAP12536	125 X 22 LUKAS FLAP DISC SLTR ZIRCONIA 36 GRIT (10)	10
FLAP12540	125 X 22 LUKAS FLAP DISC SLTR ZIRCONIA 40 GRIT (10)	10
FLAP12560	125 X 22 LUKAS FLAP DISC SLTR ZIRCONIA 60 GRIT (10)	10
FLAP12580	125 X 22 LUKAS FLAP DISC SLTR ZIRCONIA 80 GRIT (10)	10
FLAP125120	125 X 22 LUKAS FLAP DISC SLTR ZIRCONIA 120 GRIT (10)	10
FLAP18036	180 X 22 LUKAS FLAP DISC SLTR ZIRCONIA 36 GRIT (10)	10
FLAP18040	180 X 22 LUKAS FLAP DISC SLTR ZIRCONIA 40 GRIT (10)	10
FLAP18060	180 X 22 LUKAS FLAP DISC SLTR ZIRCONIA 60 GRIT (10)	10
FLAP18080	180 X 22 LUKAS FLAP DISC SLTR ZIRCONIA 80 GRIT (10)	10
FLAP180120	180 X 22 LUKAS FLAP DISC SLTR ZIRCONIA 120 GRIT (10)	10



Grinding Discs

Inox & Steel



PART #		PACK QTY
GRI100	100 X 6 X 16 LUKAS GRINDING A24U-BF INOX (PREMIUMFLEX)	10
GRI115	115 X 6 X 22 LUKAS GRINDING A24U-BF INOX (PREMIUMFLEX)	10
GRI125	125 X 6 X 22 LUKAS GRINDING A24U-BF INOX (PREMIUMFLEX)	10
GRI125PF	125 X 6 X 22 LUKAS GRINDING A24U-BF STEEL (PREMIUMFLEX)	10
GRI180	180 X 6 X 22 LUKAS GRINDING A24U-BF INOX (PREMIUMFLEX)	10
GRI230	230 X 6 X 22 LUKAS GRINDING A24U-BF INOX(PREMIUMFLEX)	10

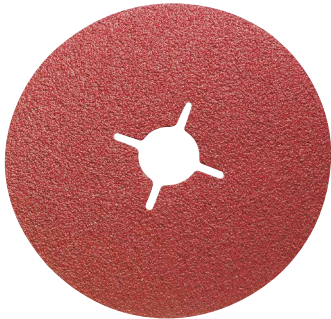

Fibre Discs

Ceramic



PART #		Grit	Material	PACK QTY
DISCFC11524	115 LUKAS FIBRE DISC FIS CERAMIC 24 GRIT (50)	24	Ceramic	50
DISCFC11536	115 LUKAS FIBRE DISC FIS CERAMIC 36 GRIT (50)	36	Ceramic	50
DISCFC11550	115 LUKAS FIBRE DISC FIS CERAMIC 50 GRIT (50)	50	Ceramic	50
DISCFC11560	115 LUKAS FIBRE DISC FIS CERAMIC 60 GRIT (50)	60	Ceramic	50
DISCFC11580	115 LUKAS FIBRE DISC FIS CERAMIC 80 GRIT (50)	80	Ceramic	50
DISCFC12524	125 LUKAS FIBRE DISC FIS CERAMIC 24 GRIT (50)	24	Ceramic	50
DISCFC12536	125 LUKAS FIBRE DISC FIS CERAMIC 36 GRIT (50)	36	Ceramic	50
DISCFC12560	125 LUKAS FIBRE DISC FIS CERAMIC 60 GRIT (50)	60	Ceramic	50
DISCFC12580	125 LUKAS FIBRE DISC FIS CERAMIC 80 GRIT (50)	80	Ceramic	50
DISCFC125120	125 LUKAS FIBRE DISC FIS CERAMIC 120 GRIT (50)	120	Ceramic	50
DISCFC18024	180 LUKAS FIBRE DISC FIS CERAMIC 24 GRIT (50)	24	Ceramic	50
DISCFC18036	180 LUKAS FIBRE DISC FIS CERAMIC 36 GRIT (50)	36	Ceramic	50

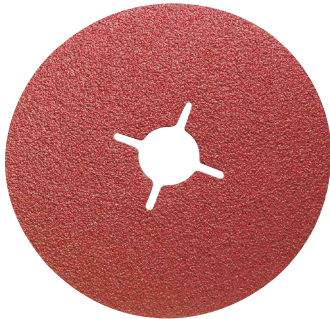

Fibre Discs

Alumnium Oxide



PART #		Grit	Material	PACK QTY
DISCF11560	115 LUKAS FIBRE DISC NK FIS 60 GRIT (50)	60	Alu Oxide	50
DISCF11580	115 LUKAS FIBRE DISC NK FIS 80 GRIT (50)	80	Alu Oxide	50
DISCF115120	115 LUKAS FIBRE DISC NK FIS 120 GRIT (50)	120	Alu Oxide	50
DISCF12524	125 LUKAS FIBRE DISC NK FIS 24 GRIT (50)	24	Alu Oxide	50
DISCF12536	125 LUKAS FIBRE DISC NK FIS 36 GRIT (50)	36	Alu Oxide	50
DISCF12540	125 LUKAS FIBRE DISC NK FIS 40 GRIT (50)	40	Alu Oxide	50
DISCF12550	125 LUKAS FIBRE DISC NK FIS 50 GRIT (50)	50	Alu Oxide	50
DISCF12560	125 LUKAS FIBRE DISC NK FIS 60 GRIT (50)	60	Alu Oxide	50
DISCF12580	125 LUKAS FIBRE DISC NK FIS 80 GRIT (50)	80	Alu Oxide	50
DISCF18016	180 LUKAS FIBRE DISC NK FIS 16 GRIT (50)	16	Alu Oxide	50
DISCF18024	180 LUKAS FIBRE DISC NK FIS 24 GRIT (50)	24	Alu Oxide	50
DISCF18036	180 LUKAS FIBRE DISC NK FIS 36 GRIT (50)	36	Alu Oxide	50
DISCF18040	180 LUKAS FIBRE DISC NK FIS 40 GRIT (50)	40	Alu Oxide	50
DISCF18060	180 LUKAS FIBRE DISC NK FIS 60 GRIT (50)	60	Alu Oxide	50
DISCF18080	180 LUKAS FIBRE DISC NK FIS 80 GRIT (50)	80	Alu Oxide	50



Backing Pads

Standard & Turbo



PART #	Description	PACK QTY
BPAD115RIB	115 FIBRE DISC LUKAS BACKING PAD WITH RIBS	1
BPAD125RIB	125 FIBRE DISC LUKAS BACKING PAD WITH RIBS	1
BPAD180RIB	180 FIBRE DISC LUKAS BACKING PAD WITH RIBS	1
BPAD150RIB	150 FIBRE DISC LUKAS BACKING PAD WITH RIBS	1
BPAD115	115 FIBRE DISC LUKAS BACKING PAD	1
BPAD125	125 FIBRE DISC LUKAS BACKING PAD	1
BPAD150	150 FIBRE DISC LUKAS BACKING PAD	1
BPAD180	180 FIBRE DISC LUKAS BACKING PAD	1



Barrel Rolls

PART #	Description	Material	PACK QTY
BARRW100C	100 X 100 X 19 LUKAS BARREL ROLL A 104	Alu Oxide	1
BARRW100M	100 X 100 X 19 LUKAS BARREL ROLL A 106	Alu Oxide	1
BARRW100F	100 X 100 X 19 LUKAS BARREL ROLL C 208	Silicon Carbide	1

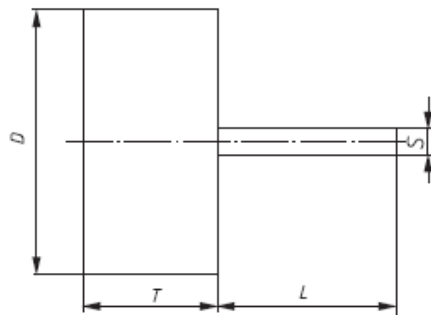

Flap Wheels

Aluminium Oxide



PART #	Description	D mm	T mm	S mm	PACK QTY
FLAPW101080	10 X 10 X 3 LUKAS LUKAS FLAP WHEEL 80 GRIT (10)	10	10	3	10
FLAPW1010120	10 X 10 X 3 LUKAS LUKAS FLAP WHEEL 120 GRIT (10)	10	10	3	10
FLAPW1010150	10 X 10 X 3 LUKAS FLAP WHEEL 150 GRIT (10)	10	10	3	10
FLAPW1010240	10 X 10 X 3 LUKAS FLAP WHEEL 240 GRIT (10)	10	10	3	10
FLAPW101580	10 X 15 X 3 LUKAS FLAP WHEEL 80 GRIT (10)	10	15	3	10
FLAPW151080	15 X 10 X 6 LUKAS FLAP WHEEL 80 GRIT (10)	15	10	6	10
FLAPW151580	15 X 15 X 3 LUKAS FLAP WHEEL 150 GRIT (10)	15	15	3	10
FLAPW1515120	15 X 15 X 3 LUKAS FLAP WHEEL 150 GRIT (10)	15	15	3	10
FLAPW1515150	15 X 15 X 3 LUKAS FLAP WHEEL 150 GRIT (10)	15	15	3	10
FLAPW2005120	20 X 5 X 6 LUKAS FLAP WHEEL 120 GRIT (10)	20	5	6	10
FLAPW201080	20 X 10 X 6 LUKAS FLAP WHEEL 80 GRIT (10)	20	10	6	10
FLAPW2010120	20 X 10 X 6 LUKAS FLAP WHEEL 120 GRIT (10)	20	10	6	10
FLAPW201560	20 X 15 X 6 LUKAS FLAP WHEEL 60 GRIT (10)	20	15	6	10
FLAPW201580	20 X 15 X 6 LUKAS FLAP WHEEL 80 GRIT (10)	20	15	6	10
FLAPW2015120	20 X 15 X 6 LUKAS FLAP WHEEL 120 GRIT (10)	20	15	6	10
FLAPW2015180	20 X 15 X 6 LUKAS FLAP WHEEL 180 GRIT (10)	20	15	6	10
FLAPW2015240	20 X 15 X 6 LUKAS FLAP WHEEL 240 GRIT (10)	20	15	6	10
FLAPW202060	20 X 20 X 6 LUKAS FLAP WHEEL 60 GRIT (10)	20	20	6	10
FLAPW202080	20 X 20 X 6 LUKAS FLAP WHEEL 80 GRIT (10)	20	20	6	10
FLAPW251080	25 X 10 X 6 LUKAS FLAP WHEEL 80 GRIT (10)	25	10	6	10
FLAPW2510120	25 X 10 X 6 LUKAS FLAP WHEEL 120 GRIT (10)	25	10	6	10
FLAPW251580	25 X 15 X 6 LUKAS FLAP WHEEL 80 GRIT (10)	25	15	6	10
FLAPW2515120	25 X 15 X 6 LUKAS FLAP WHEEL 120 GRIT (10)	25	15	6	10
FLAPW2515150	25 X 15 X 6 LUKAS FLAP WHEEL 150 GRIT (10)	25	15	6	10
FLAPW2520120	25 X 20 X 6 LUKAS FLAP WHEEL 120 GRIT (10)	25	20	6	10
FLAPW252580	25 X 25 X 6 LUKAS FLAP WHEEL 80 GRIT (10)	25	25	6	10
FLAPW2525150	25 X 25 X 6 LUKAS FLAP WHEEL 150 GRIT (10)	25	25	6	10

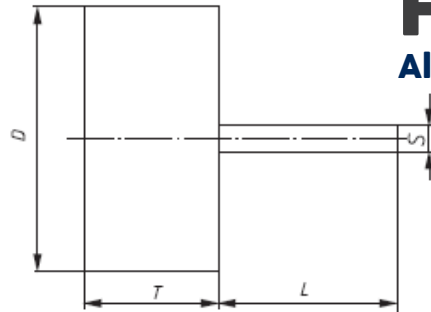
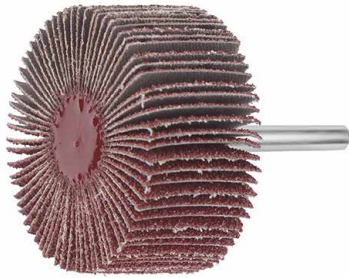

Flap Wheels

Alumnium Oxide



PART #	Description	D mm	T mm	S mm	PACK QTY
FLAPW252080	25 X 20 X 6 LUKAS FLAP WHEEL 80 GRIT (10)	25	20	6	10
FLAPW2520120	25 X 20 X 6 LUKAS FLAP WHEEL 120 GRIT (10)	25	20	6	10
FLAPW252580	25 X 25 X 6 LUKAS FLAP WHEEL 80 GRIT (10)	25	25	6	10
FLAPW2525150	25 X 25 X 6 LUKAS FLAP WHEEL 150 GRIT (10)	25	25	6	10
FLAPW300560	30 X 5 X 6 LUKAS FLAP WHEEL 60 GRIT (10)	30	5	6	10
FLAPW300580	30 X 5 X 6 LUKAS FLAP WHEEL 80 GRIT (10)	30	5	6	10
FLAPW3005100	30 X 5 X 6 LUKAS FLAP WHEEL 100 GRIT (10)	30	5	6	10
FLAPW3005120	30 X 5 X 6 LUKAS FLAP WHEEL 120 GRIT (10)	30	5	6	10
FLAPW3005150	30 X 5 X 6 LUKAS FLAP WHEEL 150 GRIT (10)	30	5	6	10
FLAPW3005180	30 X 5 X 6 LUKAS FLAP WHEEL 180 GRIT (10)	30	5	6	10
FLAPW3005240	30 X 5 X 6 LUKAS FLAP WHEEL 240 GRIT (10)	30	5	6	10
FLAPW3005320	30 X 5 X 6 LUKAS FLAP WHEEL 320 GRIT (10)	30	5	6	10
FLAPW301060	30 X 10 X 6 LUKAS FLAP WHEEL 60 GRIT (10)	30	10	6	10
FLAPW301080	30 X 10 X 6 LUKAS FLAP WHEEL 80 GRIT (10)	30	10	6	10
FLAPW3010100	30 X 10 X 6 LUKAS FLAP WHEEL 100 GRIT (10)	30	10	6	10
FLAPW3010120	30 X 10 X 6 LUKAS FLAP WHEEL 120 GRIT (10)	30	10	6	10
FLAPW3010150	30 X 10 X 6 LUKAS FLAP WHEEL 150 GRIT (10)	30	10	6	10
FLAPW3010180	30 X 10 X 6 LUKAS FLAP WHEEL 180 GRIT (10)	30	10	6	10
FLAPW3010240	30 X 10 X 6 LUKAS FLAP WHEEL 240 GRIT (10)	30	10	6	10
FLAPW3010320	30 X 15 X 6 LUKAS FLAP WHEEL 320 GRIT (10)	30	15	6	10
FLAPW301560	30 X 15 X 6 LUKAS FLAP WHEEL 60 GRIT (10)	30	15	6	10
FLAPW301580	30 X 15 X 6 LUKAS FLAP WHEEL 80 GRIT (10)	30	15	6	10
FLAPW3015120	30 X 15 X 6 LUKAS FLAP WHEEL 120 GRIT (10)	30	15	6	10
FLAPW3015150	30 X 15 X 6 LUKAS FLAP WHEEL 150 GRIT (10)	30	15	6	10
FLAPW3015180	30 X 15 X 6 LUKAS FLAP WHEEL 180 GRIT (10)	30	15	6	10
FLAPW302040	30 X 20 X 6 LUKAS FLAP WHEEL 40 GRIT (10)	30	20	6	10
FLAPW302060	30 X 20 X 6 LUKAS FLAP WHEEL 60 GRIT (10)	30	20	6	10
FLAPW302080	30 X 20 X 6 LUKAS FLAP WHEEL 80 GRIT (10)	30	20	6	10
FLAPW3020120	30 X 20 X 6 LUKAS FLAP WHEEL 120 GRIT (10)	30	20	6	10

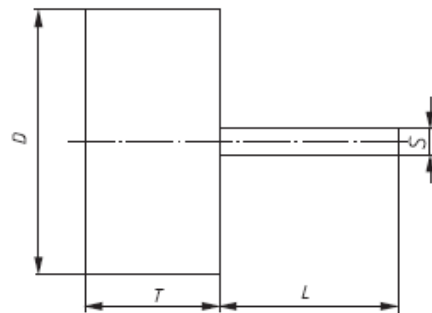

Flap Wheels

Aluminium Oxide



PART #	Description	D mm	T mm	S mm	PACK QTY
FLAPW4005100	40 X 5 X 6 LUKAS FLAP WHEEL 100 GRIT (10)	40	5	6	10
FLAPW401060	40 X 10 X 6 LUKAS FLAP WHEEL 60 GRIT (10)	40	10	6	10
FLAPW401080	40 X 10 X 6 LUKAS FLAP WHEEL 80 GRIT (10)	40	10	6	10
FLAPW4010100	40 X 10 X 6 LUKAS FLAP WHEEL 100 GRIT (10)	40	10	6	10
FLAPW4010120	40 X 10 X 6 LUKAS FLAP WHEEL 120 GRIT (10)	40	10	6	10
FLAPW4010150	40 X 10 X 6 LUKAS FLAP WHEEL 150 GRIT (10)	40	10	6	10
FLAPW4010180	40 X 10 X 6 LUKAS FLAP WHEEL 180 GRIT (10)	40	10	6	10
FLAPW4010240	40 X 10 X 6 LUKAS FLAP WHEEL 240 GRIT (10)	40	10	6	10
FLAPW4010320	40 X 10 X 6 LUKAS FLAP WHEEL 320 GRIT (10)	40	10	6	10
FLAPW401540	40 X 15 X 6 LUKAS FLAP WHEEL 40 GRIT (10)	40	15	6	10
FLAPW401560	40 X 15 X 6 LUKAS FLAP WHEEL 60 GRIT (10)	40	15	6	10
FLAPW401580	40 X 15 X 6 LUKAS FLAP WHEEL 80 GRIT (10)	40	15	6	10
FLAPW4015120	40 X 15 X 6 LUKAS FLAP WHEEL 120 GRIT (10)	40	15	6	10
FLAPW4015150	40 X 15 X 6 LUKAS FLAP WHEEL 150 GRIT (10)	40	15	6	10
FLAPW4015240	40 X 15 X 6 LUKAS FLAP WHEEL 240 GRIT (10)	40	15	6	10
FLAPW4015320	40 X 15 X 6 LUKAS FLAP WHEEL 320 GRIT (10)	40	15	6	10
FLAPW402040	40 X 20 X 6 LUKAS FLAP WHEEL 40 GRIT (10)	40	20	6	10
FLAPW402060	40 X 20 X 6 LUKAS FLAP WHEEL 60 GRIT (10)	40	20	6	10
FLAPW402080	40 X 20 X 6 LUKAS FLAP WHEEL 80 GRIT (10)	40	20	6	10
FLAPW4020120	40 X 20 X 6 LUKAS FLAP WHEEL 120 GRIT (10)	40	20	6	10
FLAPW4020150	40 X 20 X 6 LUKAS FLAP WHEEL 150 GRIT (10)	40	20	6	10
FLAPW4020240	40 X 20 X 6 LUKAS FLAP WHEEL 240 GRIT (10)	40	20	6	10
FLAPW4020320	40 X 20 X 6 LUKAS FLAP WHEEL 320 GRIT (10)	40	20	6	10
FLAPW403040	40 X 30 X 6 LUKAS FLAP WHEEL 40 GRIT (10)	40	30	6	10
FLAPW403060	40 X 30 X 6 LUKAS FLAP WHEEL 60 GRIT (10)	40	30	6	10
FLAPW403080	40 X 30 X 6 LUKAS FLAP WHEEL 80 GRIT (10)	40	30	6	10
FLAPW2525150	25 X 25 X 6 LUKAS FLAP WHEEL 150 GRIT (10)	25	25	6	10

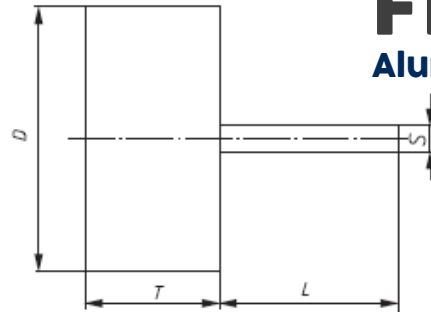
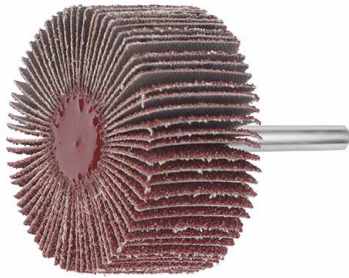

Flap Wheels

Alumnium Oxide



PART #	Description	D mm	T mm	S mm	PACK QTY
FLAPW5005100	50 X 5 X 6 LUKAS FLAP WHEEL 100 GRIT (10)	50	5	6	10
FLAPW501060	50 X 10 X 6 LUKAS FLAP WHEEL 60 GRIT (10)	50	10	6	10
FLAPW501080	50 X 10 X 6 LUKAS FLAP WHEEL 80 GRIT (10)	50	10	6	10
FLAPW5010100	50 X 10 X 6 LUKAS FLAP WHEEL 100 GRIT (10)	50	10	6	10
FLAPW5010120	50 X 10 X 6 LUKAS FLAP WHEEL 120 GRIT (10)	50	10	6	10
FLAPW5010150	50 X 10 X 6 LUKAS FLAP WHEEL 150 GRIT (10)	50	10	6	10
FLAPW5010180	50 X 10 X 6 LUKAS FLAP WHEEL 180 GRIT (10)	50	10	6	10
FLAPW5010240	50 X 10 X 6 LUKAS FLAP WHEEL 240 GRIT (10)	50	10	6	10
FLAPW501540	50 X 15 X 6 LUKAS FLAP WHEEL 40 GRIT (10)	50	15	6	10
FLAPW5015120	50 X 15 X 6 LUKAS FLAP WHEEL 120 GRIT (10)	50	15	6	10
FLAPW5015150	50 X 15 X 6 LUKAS FLAP WHEEL 150 GRIT (10)	50	15	6	10
FLAPW5015240	50 X 15 X 6 LUKAS FLAP WHEEL 240 GRIT (10)	50	15	6	10
FLAPW5015320	50 X 15 X 6 LUKAS FLAP WHEEL 320 GRIT (10)	50	15	6	10
FLAPW501560	50 X 15 X 6 LUKAS FLAP WHEEL 60 GRIT (10)	50	15	6	10
FLAPW501580	50 X 15 X 6 LUKAS FLAP WHEEL 80 GRIT (10)	50	15	6	10
FLAPW502040	50 X 20 X 6 LUKAS FLAP WHEEL 240 GRIT (10)	50	20	6	10
FLAPW502060	50 X 20 X 6 LUKAS FLAP WHEEL 60 GRIT (10)	50	20	6	10
FLAPW502080	50 X 20 X 6 LUKAS FLAP WHEEL 80 GRIT (10)	50	20	6	10
FLAPW5020120	50 X 20 X 6 LUKAS FLAP WHEEL 120 GRIT (10)	50	20	6	10
FLAPW5020150	50 X 20 X 6 LUKAS FLAP WHEEL 150 GRIT (10)	50	20	6	10
FLAPW5020240	50 X 20 X 6 LUKAS FLAP WHEEL 240 GRIT (10)	50	20	6	10
FLAPW5020320	50 X 20 X 6 LUKAS FLAP WHEEL 320 GRIT (10)	50	20	6	10
FLAPW503040	50 X 30 X 6 LUKAS FLAP WHEEL 40 GRIT (10)	50	30	6	10
FLAPW503060	50 X 30 X 6 LUKAS FLAP WHEEL 60 GRIT (10)	50	30	6	10
FLAPW503080	50 X 30 X 6 LUKAS FLAP WHEEL 80 GRIT (10)	50	30	6	10
FLAPW5030120	50 X 30 X 6 LUKAS FLAP WHEEL 120 GRIT (10)	50	30	6	10
FLAPW5030150	50 X 30 X 6 LUKAS FLAP WHEEL 150 GRIT (10)	50	30	6	10
FLAPW5030320	50 X 30 X 6 LUKAS FLAP WHEEL 320 GRIT (10)	50	30	6	10
FLAPW2525150	25 X 25 X 6 LUKAS FLAP WHEEL 150 GRIT (10)	25	25	6	10

Flap Wheels

Aluminium oxide

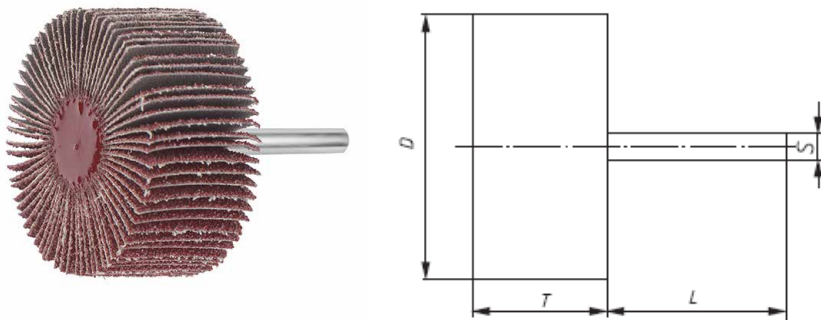

PART #	Description	D mm	T mm	S mm	PACK QTY
FLAPW601060	60 X 10 X 6 LUKAS FLAP WHEEL 60 GRIT (10)	60	10	6	10
FLAPW601080	60 X 10 X 6 LUKAS FLAP WHEEL 80 GRIT (10)	60	10	6	10
FLAPW6010100	60 X 10 X 6 LUKAS FLAP WHEEL 100 GRIT (10)	60	10	6	10
FLAPW601540	60 X 15 X 6 LUKAS FLAP WHEEL 40 GRIT (10)	60	15	6	10
FLAPW601560	60 X 15 X 6 LUKAS FLAP WHEEL 60 GRIT (10)	60	15	6	10
FLAPW601580	60 X 15 X 6 LUKAS FLAP WHEEL 80 GRIT (10)	60	15	6	10
FLAPW6015120	60 X 15 X 6 LUKAS FLAP WHEEL 120 GRIT (10)	60	15	6	10
FLAPW6015150	60 X 15 X 6 LUKAS FLAP WHEEL 150 GRIT (10)	60	15	6	10
FLAPW6015240	60 X 15 X 6 LUKAS FLAP WHEEL 240 GRIT (10)	60	15	6	10
FLAPW6015320	60 X 15 X 6 LUKAS FLAP WHEEL 320 GRIT (10)	60	15	6	10
FLAPW602040	60 X 20 X 6 LUKAS FLAP WHEEL 40 GRIT (10)	60	20	6	10
FLAPW602060	60 X 20 X 6 LUKAS FLAP WHEEL 60 GRIT (10)	60	20	6	10
FLAPW602080	60 X 20 X 6 LUKAS FLAP WHEEL 80 GRIT (10)	60	20	6	10
FLAPW6020120	60 X 20 X 6 LUKAS FLAP WHEEL 120 GRIT (10)	60	20	6	10
FLAPW6020150	60 X 20 X 6 LUKAS FLAP WHEEL 150 GRIT (10)	60	20	6	10
FLAPW6020240	60 X 20 X 6 LUKAS FLAP WHEEL 240 GRIT (10)	60	20	6	10
FLAPW6020320	60 X 20 X 6 LUKAS FLAP WHEEL 320 GRIT (10)	60	20	6	10
FLAPW603040	60 X 30 X 6 LUKAS FLAP WHEEL 40 GRIT (10)	60	30	6	10
FLAPW603060	60 X 30 X 6 LUKAS FLAP WHEEL 60 GRIT (10)	60	30	6	10
FLAPW603080	60 X 30 X 6 LUKAS FLAP WHEEL 80 GRIT (10)	60	30	6	10
FLAPW6030100	60 X 30 X 6 LUKAS FLAP WHEEL 100 GRIT (10)	60	30	6	10
FLAPW6030120	60 X 30 X 6 LUKAS FLAP WHEEL 120 GRIT (10)	60	30	6	10
FLAPW6030150	60 X 30 X 6 LUKAS FLAP WHEEL 150 GRIT (10)	60	30	6	10
FLAPW6030240	60 X 30 X 6 LUKAS FLAP WHEEL 240 GRIT (10)	60	30	6	10
FLAPW6030320	60 X 30 X 6 LUKAS FLAP WHEEL 320 GRIT (10)	60	30	6	10

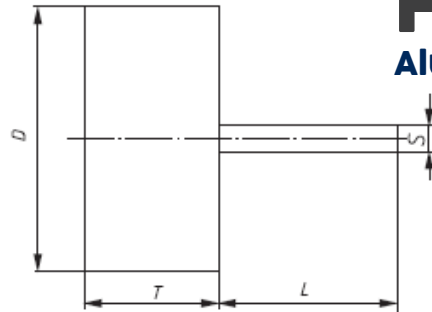
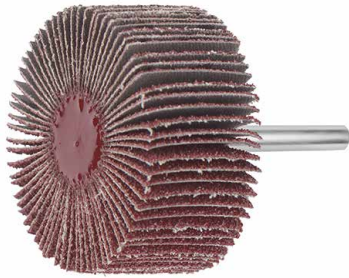

Flap Wheels

Alumnium Oxide



PART #	Description	D mm	T mm	S mm	PACK QTY
FLAPW604040	60 X 40 X 6 LUKAS FLAP WHEEL 40 GRIT (10)	60	40	6	10
FLAPW604060	60 X 40 X 6 LUKAS FLAP WHEEL 60 GRIT (10)	60	40	6	10
FLAPW604080	60 X 40 X 6 LUKAS FLAP WHEEL 80 GRIT (10)	60	40	6	10
FLAPW6040120	60 X 40 X 6 LUKAS FLAP WHEEL 120 GRIT (10)	60	40	6	10
FLAPW6040150	60 X 40 X 6 LUKAS FLAP WHEEL 150 GRIT (10)	60	40	6	10
FLAPW6040240	60 X 40 X 6 LUKAS FLAP WHEEL 240 GRIT (10)	60	40	6	10
FLAPW6040320	60 X 40 X 6 LUKAS FLAP WHEEL 320 GRIT (10)	60	40	6	10
FLAPW605040	60 X 50 X 6 LUKAS FLAP WHEEL 40 GRIT (10)	60	50	6	10
FLAPW605060	60 X 50 X 6 LUKAS FLAP WHEEL 60 GRIT (10)	60	50	6	10
FLAPW605080	60 X 50 X 6 LUKAS FLAP WHEEL 80 GRIT (10)	60	50	6	10
FLAPW6050120	60 X 50 X 6 LUKAS FLAP WHEEL 120 GRIT (10)	60	50	6	10
FLAPW6050150	60 X 50 X 6 LUKAS FLAP WHEEL 150 GRIT (10)	60	50	6	10
FLAPW6050240	60 X 50 X 6 LUKAS LUKAS FLAP WHEEL 240 GRIT (10)	60	50	6	10



HFA Burrs

Base -X Retail Range ZX Cut

PART #	Description	PACK QTY
BURRCYLCUT313P	3 X 13 X 3 HFA LUKAS CYLINDRICAL BURR HC (1)	1
BURRCYLCUT820P	8 X 20 X 6 HFA LUKAS CYLINDRICAL BURR HC (1)	1
BURRCYLCUT1225P	12 X 25 X 6 HFA LUKAS CYLINDRICAL BURR HC (1)	1

HFD Burrs

Base -X Retail Range ZX Cut



PART #	Description	PACK QTY
BURRSPHER65P	6 X 5 X 3 HFD LUKAS SPHERICAL BURR HC (1)	1
BURRSPHER87P	8 X 7 X 6 HFD LUKAS SPHERICAL BURR HC (1)	1
BURRSPHER1210P	12 X 10 X 6 HFD LUKAS SPHERICAL BURR HC (1)	1



HFF Burrs

Base -X Retail Range ZX Cut

PART #	Description	PACK QTY
BURRARCRND820P	8 X 20 X 6 HFF LUKAS ARCH ROUND NOSE BURR HC (1)	1
BURRARCRND1225P	12 X 25 X 6 HFF LUKAS ARCH ROUND NOSE BURR HC (1)	1

HFG Burrs

Base -X Retail Range ZX Cut



PART #	Description	PACK QTY
BURRARCPNT313P	3 X 13 X 3 HFG LUKAS ARCH POINTED NOSE BURR HC (1)	1
BURRARCPNT820P	8 X 20 X 6 HFG LUKAS ARCH POINTED NOSE BURR HC (1)	1
BURRARCPNT1225P	12 X 25 X 6 HFG LUKAS ARCH POINTED NOSE BURR HC (1)	1



HFC Burrs

Base -X Retail Range ZX Cut

PART #	Description	PACK QTY
BURRCYLrnd313P	3 X 13 X 3 HFC LUKAS CYLINDRICAL ROUND NOSE BURR HC (1)	1
BURRCYLrnd820P	8 X 20 X 6 HFC LUKAS CYLINDRICAL ROUND NOSE BURR HC (1)	1
BURRCYLrnd1225P	12 X 25 X 6 HFC LUKAS CYLINDRICAL ROUND NOSE BURR HC (1)	1



HFM Burrs

Base -X Retail Range ZX Cut

PART #	Description	PACK QTY
BURRCONPnt311P	3 X 11 X 3 HFM LUKAS CONICAL POINTED NOSE BURR HC (1)	1



Diamond Wheels

Blue Cut



PART #	Description	PACK QTY
CUTDIA115P	115 x 22 DIAMOND LUKAS CUT OFF WHEEL 80m/s HC (1)	1
CUTDIA125P	125 x 22 DIAMOND LUKAS CUT OFF WHEEL 80m/s HC (1)	1
CUTDIA180P	180 x 22 DIAMOND LUKAS CUT OFF WHEEL 80m/s HC (1)	1
CUTDIA230P	230 x 22 DIAMOND LUKAS CUT OFF WHEEL 80m/s HC (1)	1



